

Schnittbild

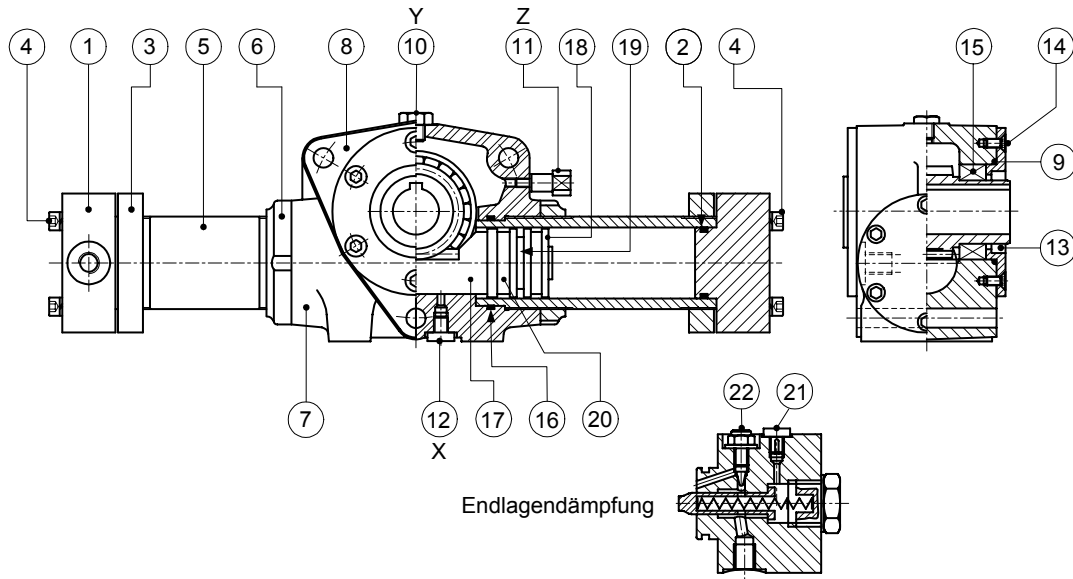

1 Zylinderboden	5 Zylinderrohr	10 Verschluss-Stopfen	13 Simmerring	17 Zahnstange	21 Entlüftungsschraube
2 O-Ring	6 Nutmutter	11 Sicherheitsventil	14 Senkschraube	18 Kolben	22 Einstellschraube
3 Kontermutter	7 Gehäuse	12 Anschluss	15 Wälzlager	19 Dichtung	Endlagendämpfung
4 Zylinderkopfschraube	8 Flansch	Hydrostatische Lagerung	16 O-Ring	20 Führungsband	
9 O-Ring					

Typenschlüssel

RA - YP - 30 - 180 - A - 90 - 0 - B

Grundbezeichnung

R	Standard-Ausführung
RA	Ausführung mit beidseitiger Endlagendämpfung

Optionen

Y	Befestigung mit Füßen
L	Abtriebswelle mit Keilnut
P	Abtriebswelle mit Vielkeilwelle nach DIN

Baugröße BG

BG	Drehmoment	Nominaldruck	Volumen bei 360°	Max. Belastung [daN]	
	[daN m]	[bar]	[dm³]	radial	axial
03	30	130	0.19	450	450
05	50	130	0.26	500	500
08	80	130	0.45	1200	1200
1	152	130	0.88	1500	1500
3	280	130	1.70	2000	1700
4	415	130	2.28	3000	3000
8	830	130	4.56	4000	3000
13	1300	130	8.3	5000	4000
20	2000	130	11.5	6000	5000
30	3000	150	14.6	8000	7000
50	5000	150	25.1	10000	10000
100	10000	165	45.5	15000	15000

Zahnstangen-Führung

A	Standard
B	Hydrostatische Lagerung

Position Federkeilnut

φ	Winkelgrad
----------	------------

Position der Druckanschlüsse

β	Winkelgrad
----------	------------

Dichtungsart

A	NBR Kompaktdichtung bis 0.5m/s, -20 bis 70°C
B	PTFE-NBR Dichtungen bis 5m/s, -20 bis 70°C
C	VITON Kompaktdichtungen bis 0.5m/s, -20 bis 70°C
D	PTFE-VITON Dichtungen bis 5m/s, -20 bis 150°C

Schwenkwinkel

α	Winkelgrad
----------	------------

Baugröße 03 bis 4

R

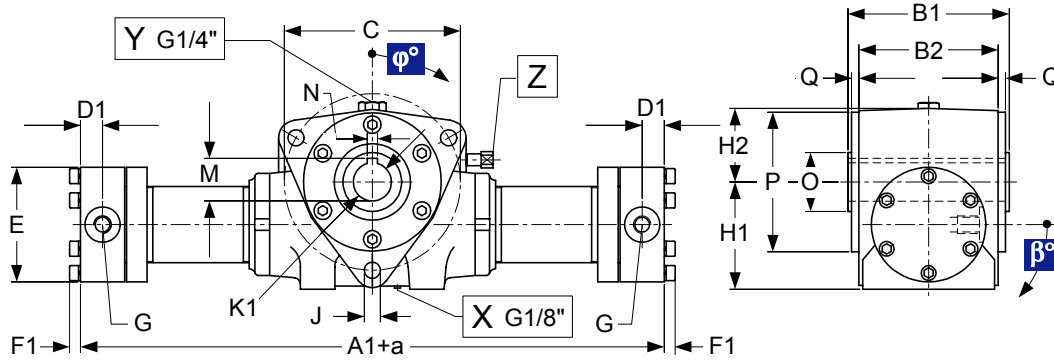

RA

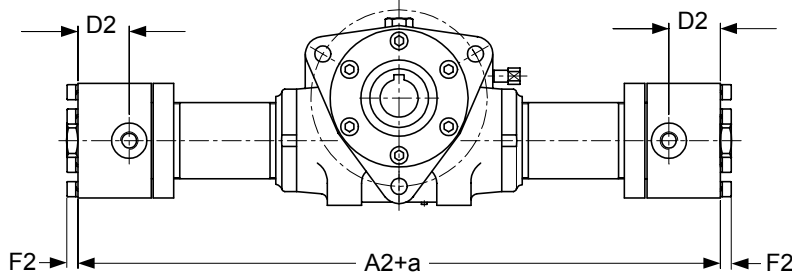

BG	A1	A2	a	B1	B2	C	D1	D2	E	F1	F2	G (G...)	H1	H2	J	K1 H8	M	N	O	P e8	Q
03	234	284	$0.838 \times \alpha^\circ$	110	95	120	15	40	78	8	12	1/4"	74	50	11	28	31.3	8	40	95	5
05	236	286	$1.117 \times \alpha^\circ$	115	100	140	15	40	78	8	12	1/4"	87	55	13	32	35.3	10	45	100	5
08	290	370	$1.257 \times \alpha^\circ$	130	110	160	20	60	96	10	10	1/2"	95	65	13	40	43.3	12	55	120	7.5
1	340	420	$1.570 \times \alpha^\circ$	145	120	195	20	60	115	13	13	1/2"	115	70	15	48	51.8	14	65	135	10
3	392	516	$1.885 \times \alpha^\circ$	160	135	240	24	86	140	15	15	3/4"	145	85	22	60	64.4	18	85	160	10
4	422	546	$2.513 \times \alpha^\circ$	205	175	285	24	86	140	15	15	3/4"	170	105	24	70	74.9	20	90	200	12.5

Optionen

L

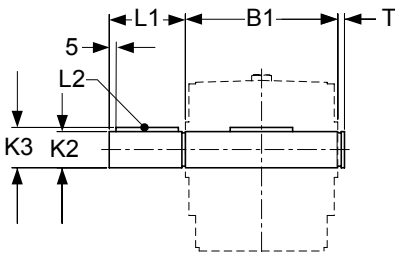

P

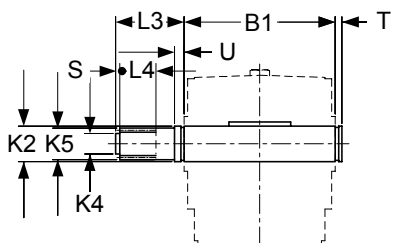

Y

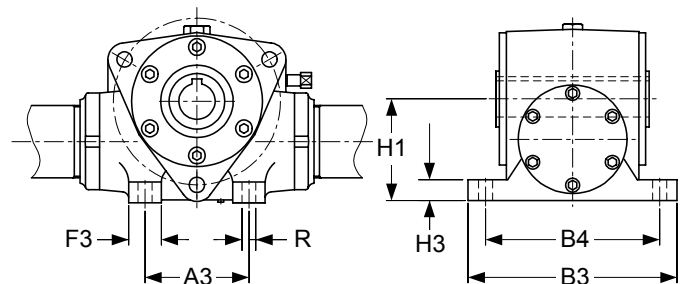

BG	A3	B1	B3	B4	F3	H1	H3	K2 f7	K3	K4 f7	K5 DIN 5482	L1	L2	L3	L4	ØR	S	T	U
03	80	110	150	125	25	74	15	28	31	20	25x22	55	8x7x45	50	25	11	3	5	
05	105	115	155	130	25	87	20	32	35	25	30x27	55	10x8x45	55	30	11	6	7	
08	120	130	175	145	32	95	25	40	43	30	38x34	60	12x8x50	55	30	13	7		
1	140	145	190	160	35	115	30	48	51.5	40	45x41	80	14x9x70	75	40	15	7	10	
3	160	160	220	180	45	145	35	60	64	50	58x53	100	18x11x90	80	40	18	5	8	10
4	210	205	260	220	55	170	40	70	74.5	60	68x62	110	20x12x100	85	45	20	8	12	

Baugröße 8 + 13

R

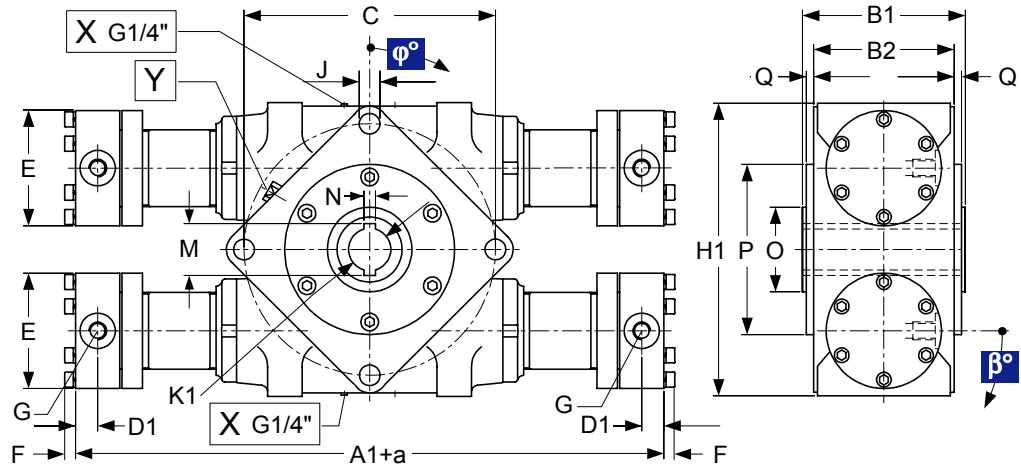

RA

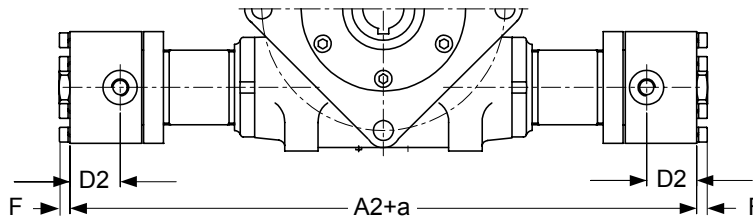

BG	A1	A2	a	B1	B2	C	D1	D2	E	F	G (G...)	H1	J	K1 H8	M	N	O	P e8	Q
8	422	546	$2.513 \times \alpha^\circ$	180	150	285	24	86	140	15	3/4"	340	26	85	95.8	22	120	205	12.5
13	492	624	$2.932 \times \alpha^\circ$	210	175	340	28	94	180	20	1"	400	29	100	112.8	28	130	235	12.5

Optionen

L

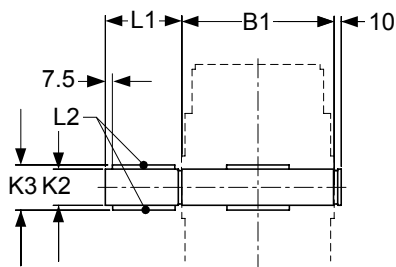

P

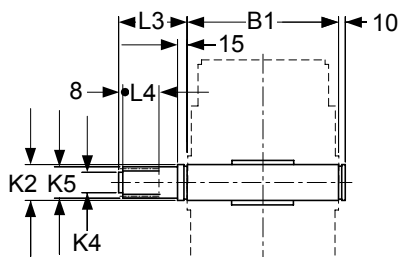

Y

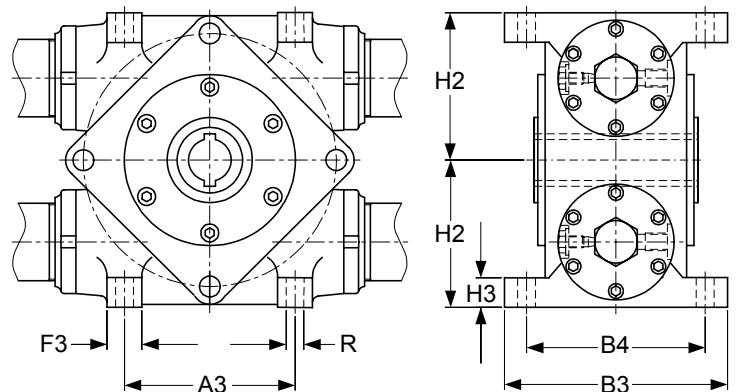

BG	A3	B1	B3	B4	F3	H2	H3	K2 f7	K3	K4 f7	K5 DIN 5482	L1	L2	L3	L4	ØR
8	230	180	240	200	55	170	50	85	95	75	82x76	120	22x14x100	100	50	20
13	280	210	280	230	65	200	60	100	112	90	98x92	140	28x16x125	105	60	22

Baugröße 20 + 30

R

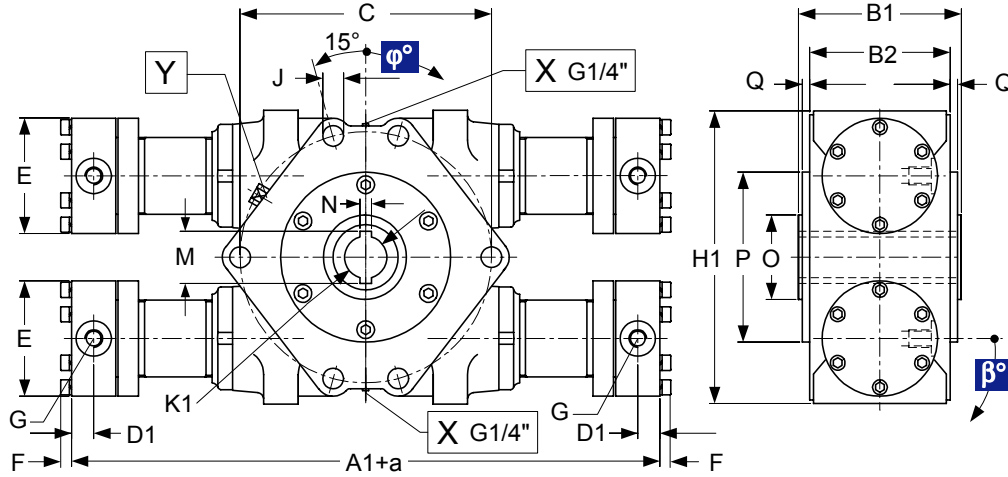

RA

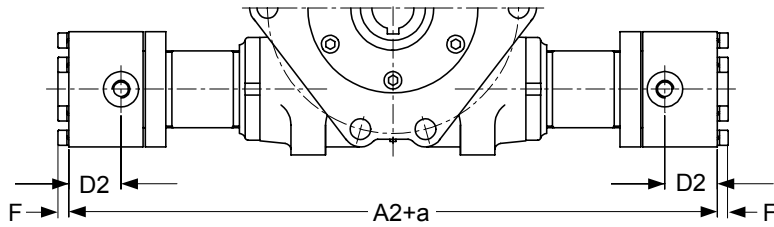

BG	A1	A2	a	B1	B2	C	D1	D2	E	F	G (G...)	H1	J	K1 H8	M	N	O	P e8	Q
20	550	740	$3.071 \times \alpha^\circ$	240	200	370	35	130	190	20	1 1/4"	430	29	120	134.8	32	150	260	15
30	610	800	$3.840 \times \alpha^\circ$	260	220	430	35	130	190	20	1 1/4"	490	32	140	156.8	36	180	300	15

Optionen

L

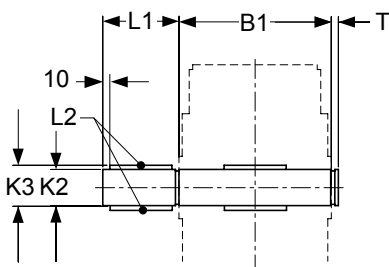

P

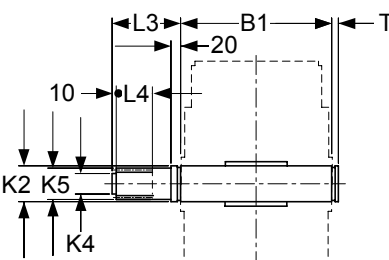

Y

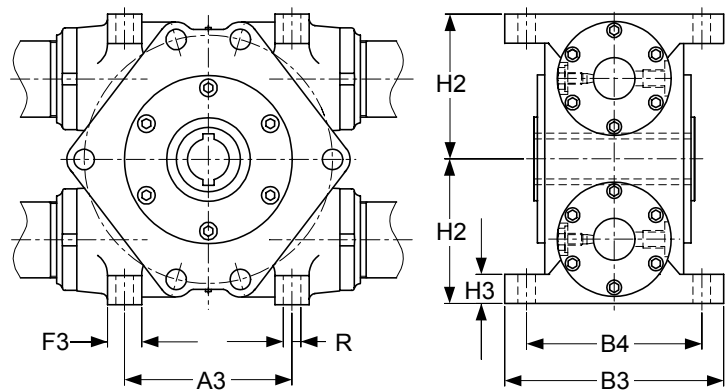

BG	A3	B1	B3	B4	F3	H2	H3	K2 f7	K3	K4 f7	K5 DIN 5480	L1	L2	L3	L4	T	ØR
20	320	240	300	250	75	215	65	120	134	110	120x112	160	32x18x140	125	70	12	26
30	370	260	340	280	85	245	70	140	156	130	140x132	180	36x20x160	135	85	15	29

Baugröße 50

R

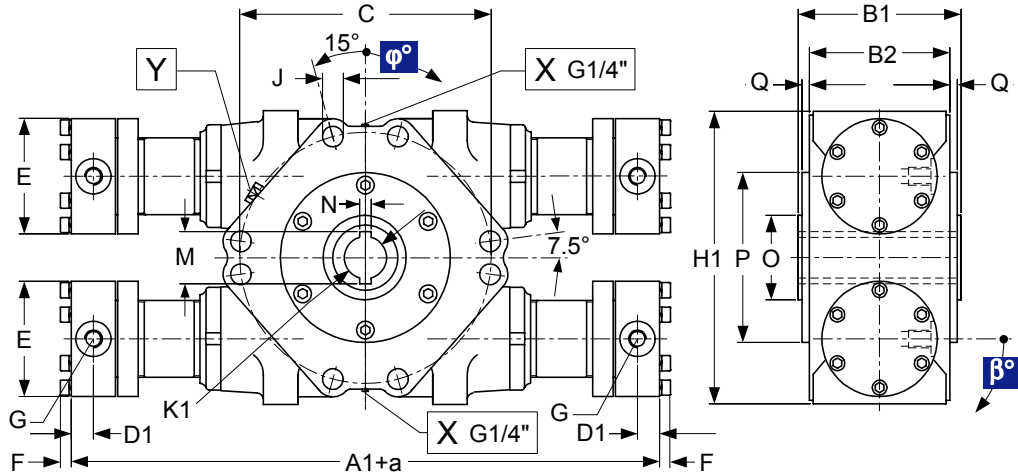

RA

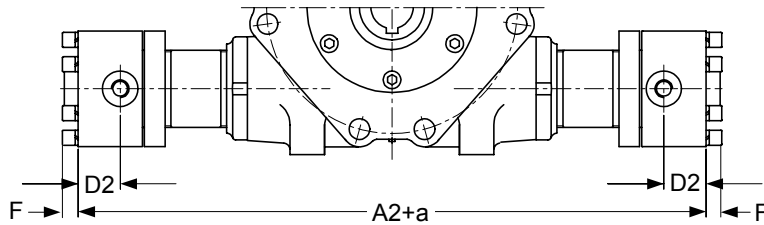

BG	A1	A2	a	B1	B2	C	D1	D2	E	F	G (G...)	H1	J	K1 H8	M	N	O	P e8	Q
50	710	950	$4.538 \times \alpha^\circ$	300	260	510	38	158	225	20	1 1/2"	570	32	155	173.8	40	200	330	15

Optionen

L

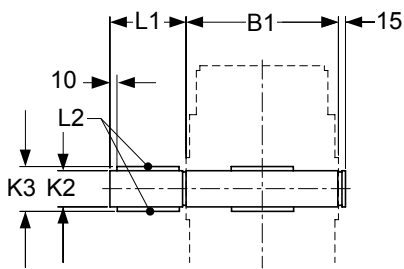

P

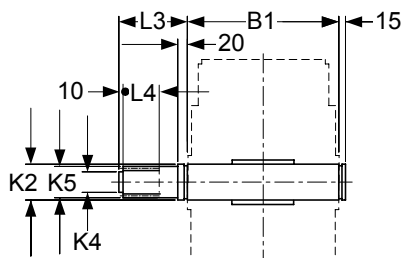

Y

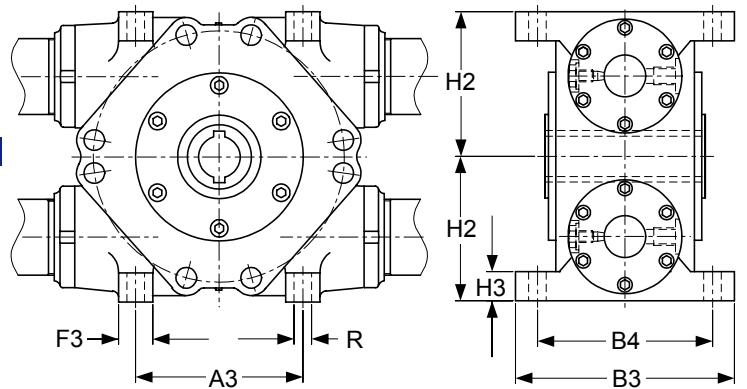

BG	A3	B1	B3	B4	F3	H2	H3	K2 f7	K3	K4 f7	K5 DIN 5480	L1	L2	L3	L4	ØR
50	420	300	380	320	100	285	80	155	173	140	150x142	200	40x22x180	150	90	32

Baugröße 100

R

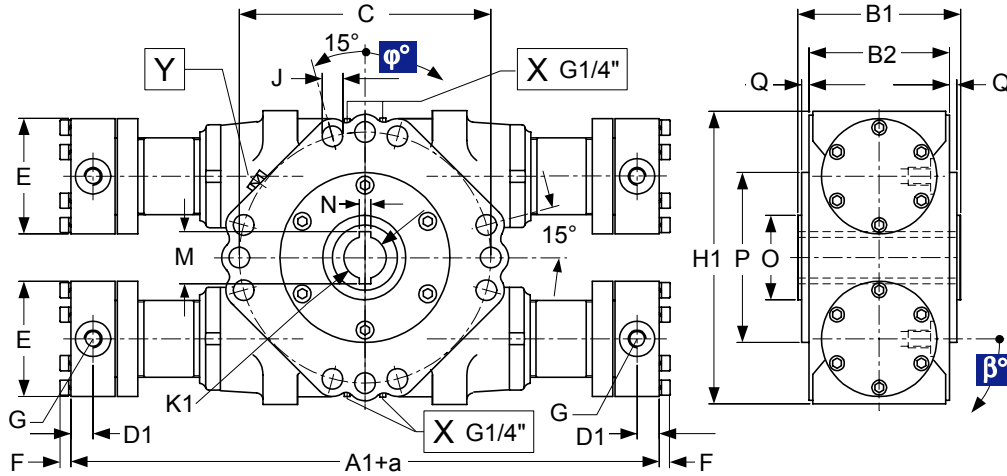

RA

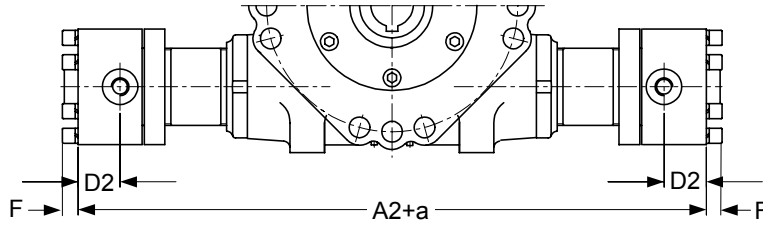

BG	A1	A2	a	B1	B2	C	D1	D2	E	F	G (G...)	H1	J	K1 H8	M	N	O	P e8	Q
100	830	1070	$6.283 \times \alpha^\circ$	340	300	675	38	158	255	25	11/2"	740	32	200	220.8	45	280	445	15

Optionen

L

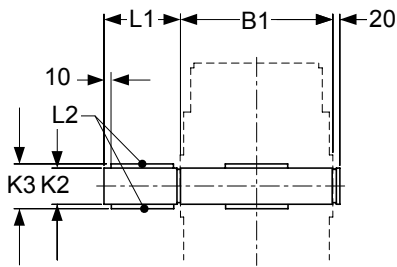

P

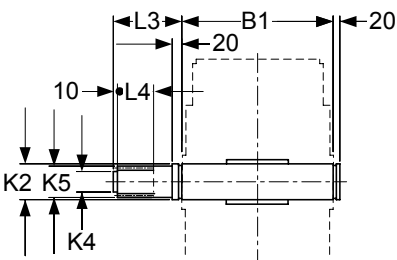

Y

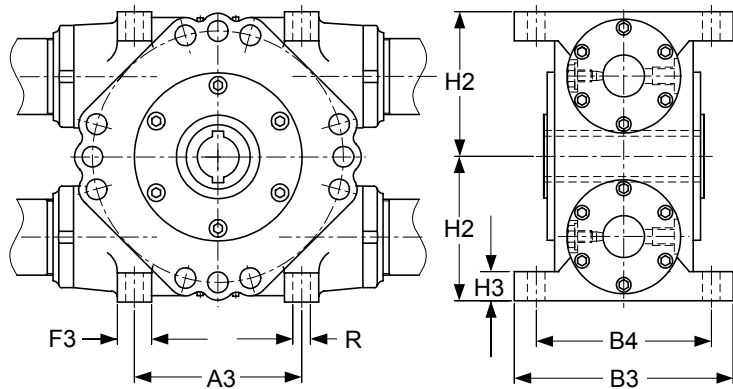

BG	A3	B1	B3	B4	F3	H2	H3	K2 f7	K3	K4 f7	K5 DIN 5480	L1	L2	L3	L4	ØR
100	590	340	460	380	110	370	100	200	220	190	200x192	240	45x25x220	175	120	38

Zahnstangen-Führung / Steuerungsart

Schwenkantriebe mit bewegten Massen müssen gegen Beschleunigungs- und Verzögerungskräfte abgesichert werden. Es empfiehlt sich der Einsatz von kombinierten Doppelbremsventilen mit Schockabsicherung entsprechend untenstehendem Schema.

Bei extremen Lastwechseln ist eine hydrostatische Lagerung der Zahnstange - Ausführung B - vorzusehen. Dadurch wird das Zahnflankenspiel reduziert und die Lebensdauer des Antriebs wesentlich verbessert. Am Schwenkantrieb sind entsprechende Druck- und Rücklaufanschlüsse (X, Y) vorgesehen.

A Ausführung standard

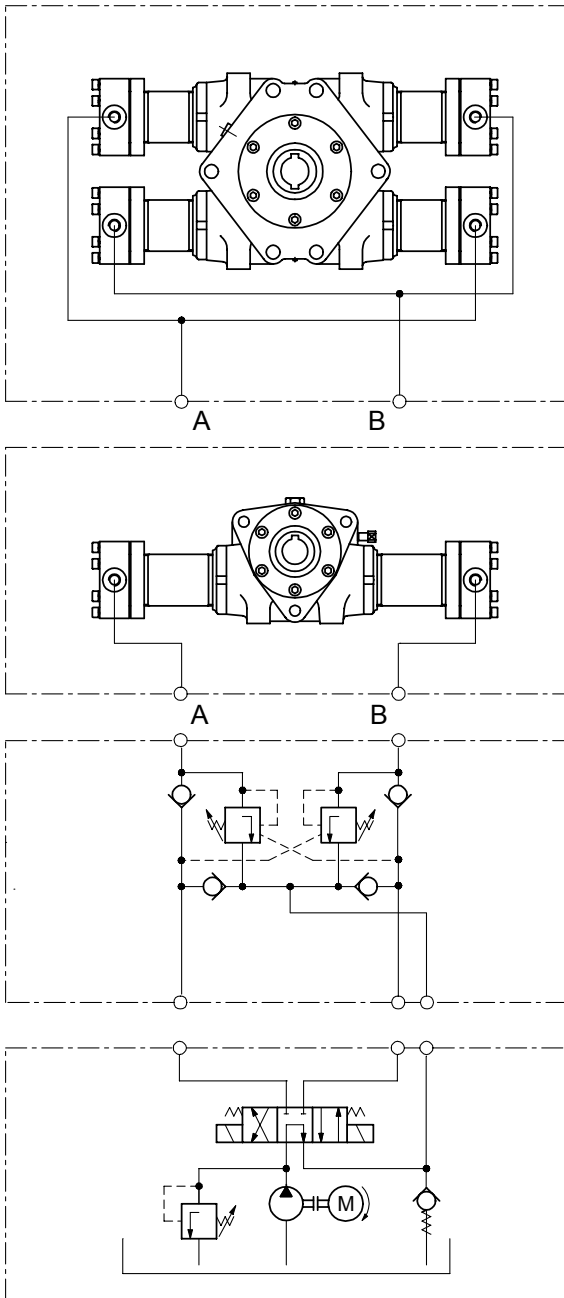

B Ausführung hydrostatische Lagerung

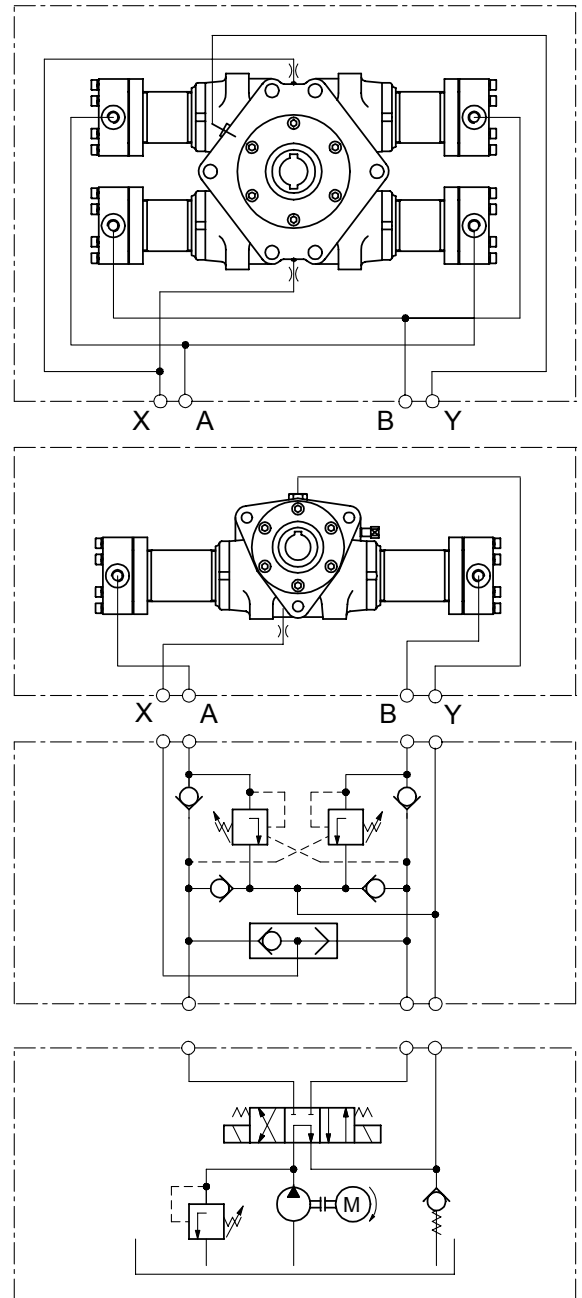

Hydrostatische Lagerung, Lecköl

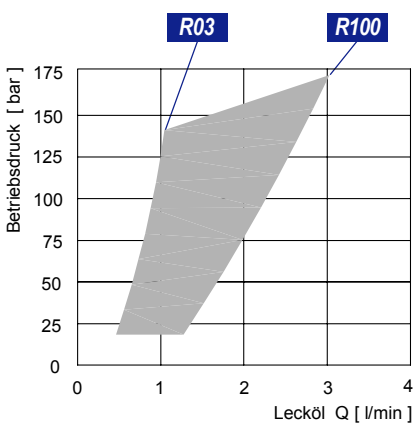

Die hydrostatische Lagerung erfordert einen zusätzlichen Volumenstrom (Verlustleistung), welcher dem nebenstehenden Diagramm entnommen werden kann. Die Ölversorgung muss entsprechend dimensioniert werden.